

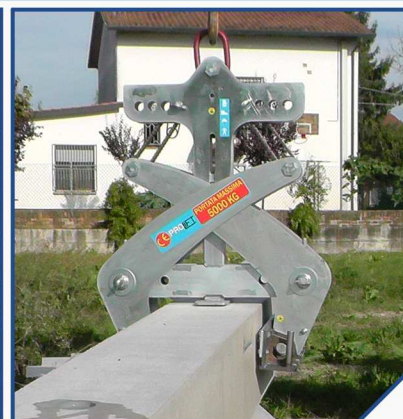

## PINZA SOLLEVAMENTO BLOCCHI

- ▶ Permette il sollevamento di blocchi in cemento di diverse dimensioni e corpi analoghi
- ▶ Dotata di serie, di bloccaggio automatico completamente meccanico
- ▶ Equipaggiabile con prese in gomma o prese in acciaio, a discrezione del cliente
- ▶ Corredata di Manuale d'Uso e Manutenzione, Elenco Ricambi
- ▶ Conforme alla Direttiva Macchine 2006/42/CE

MODELLO	PORTATA MASSIMA (kg)	APERTURA (mm)
PB030510	3000	500÷1000
PB031015		1000÷1500
PB050510	5000	500÷1000
PB051015		1000÷1500

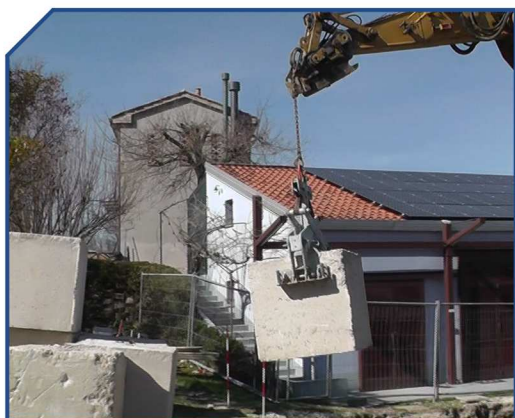
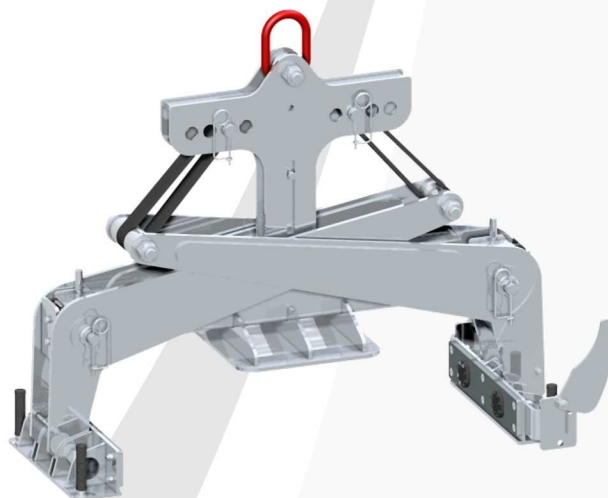

**PROLIFT**

